

Hectronic

*Smart Solutions for
parking and refuelling*



User Manual

Level Controller

NK411 / NK412

TU1.5010.0100.03.02

www.hectronic.com

HelpDesk

The HelpDesk system is used to assist our support team and offers you quick and uncomplicated assistance for requests.

Tickets: Each support request will be input as a so-called "Ticket" in the HelpDesk system.

Your benefits: **Clarity:** Each request will receive its own ticket number. This helps to view the details to your request at any time and to refer to the number in case of queries.

Fast help: Online requests are passed on directly and with all information required to the responsible technician.

Transparency: The HelpDesk system guarantees the transparency of running and completed processes at any moment - even when the technician processing your case should be unavailable.

How is a ticket generated?

Online: The ideal way is generating a ticket via our online HelpDesk system, which can be reached comfortable via our homepage (*Service > Helpdesk*). After the initial creation of a user account you can immediately start to create requests.

Detailed information on the use of the online HelpDesk system is available. You can also download the instructions in the member area of our homepage. Upon registration (*Login*) the navigation bar shows the menu item > Member.

There you find the PDF-file under *Tank Content Management > HelpDesk*.

By phone: Certainly, you can also reach our technicians by phone. However, kindly note that tickets generated online ensure safe and efficient processing. Requests by phone first have to be generated and assigned manually by our technicians. This may partly influence our response times.

Hotline number: +49 7703 9388-994

Please help us by having the following information at hand:

- Your contact data (phone number and email address under which you can be reached in person)
- Precise description of the problem or error message

Procedure:

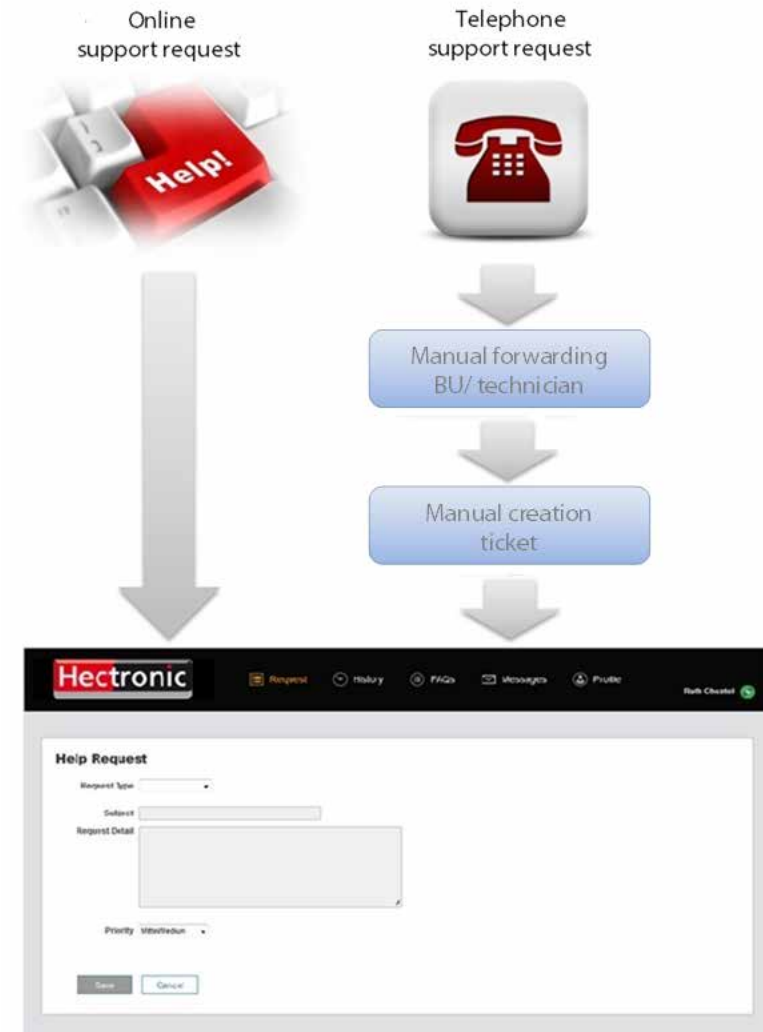

Date	Revision	Release	Chapter	Description
11/2017	00			First edition
04/2018	01		1.4 1.4.1/1.4. 1.5 2.3	Overfill prevention approval updated Wiring diagram updated Technical data updated Wiring diagram updated
08/2021	02		General 1.4 7.3	New number key for technical documentation Technical data updated New ATEX Certificate (EU-Type Examination Certificate)
06/2023	03		1.3 & 1.5 6	KVU updated EU Declaration of Conformity updated

General Introduction	9	1
Intended use	10	
Function	10	
Application	11	
Technical data	13	
Type plate	14	
Installation	15	2
Device dimensions	16	
Mounting	16	
Installation	17	
Connection	19	
Signals and Control Elements	21	3
Signals	22	
Control elements	23	
Operation	25	4
Operation	26	
Periodic functional testing	27	
Alarm reset mode	27	
LED Indicators	29	5
Certificates	33	6
EU Declaration of Conformity	35	
IECEx Certificate of Conformity	37	
ATEX Certificate	43	
Warranty Protocol	47	7

1. General Introduction

1.1. Intended Use

The level controller NK41x is a self-monitoring control unit for the error-free control and monitoring of HecoFill probes.

If the unit is used in a manner not specified within this manual the protection provided by the device may be impaired!

1.2. Function

The NK41x level controller contains the supply and ex-barriers for the intrinsically safe HecoFill probe and the circuit components necessary for signal analysis. Two relays (with changeover contacts) for limit value monitoring can be used to activate alarms or for fill level regulation. The switching status is displayed visually by LEDs.

The HecoFill probes work according to the optoelectronic measuring principle: The probe contains an infrared LED and a light receiver. The light of the LED is directed into a prism which forms the tip of the sensor. As long as the tip is not dipped into a fluid, the light is reflected within the prism to the receiver.

When rising liquid immerses the tip of the prism, the light is refracted out into the liquid, leaving little or no light to reach the receiver. Sensing this change, the receiver actuates electronic switching. This switching process is evaluated through an error-proof process as the alarm limit value, operating the potential-free relay changeover contacts.

HecoFill probes are intrinsically ex-safe and can be used in explosion zone 0 when installed as specified.

1.3. Application

The level controller (NK411 or NK412) forms together with the optoelectronic HecoFill series probe a measuring system for monitoring liquid levels.

The devices and probes meet the highest requirements and have the following approvals:

- Special level indicator in accordance with KVV (CH) KVV 302.028
- Overflow prevention in accordance with WHG (D) Z-65.14-571

Other applications with high safety requirements:

- Level control
- Process control
- Pump control

1.3.1. Special Limit Indicator

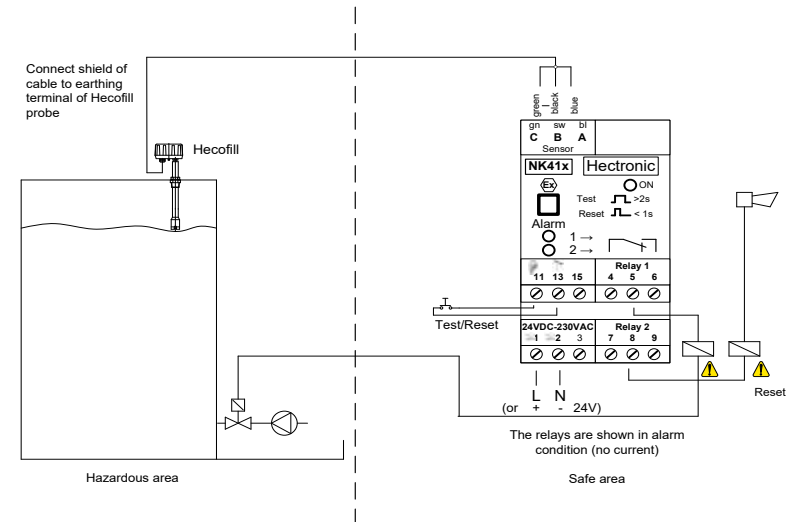

Warning! Use the terminals on the **bottom left** of the controller to connect the supply line. Connecting to the wrong terminal may destroy the device.

1

2

3

4

5

6

7

1.3.2. Leak Detection System

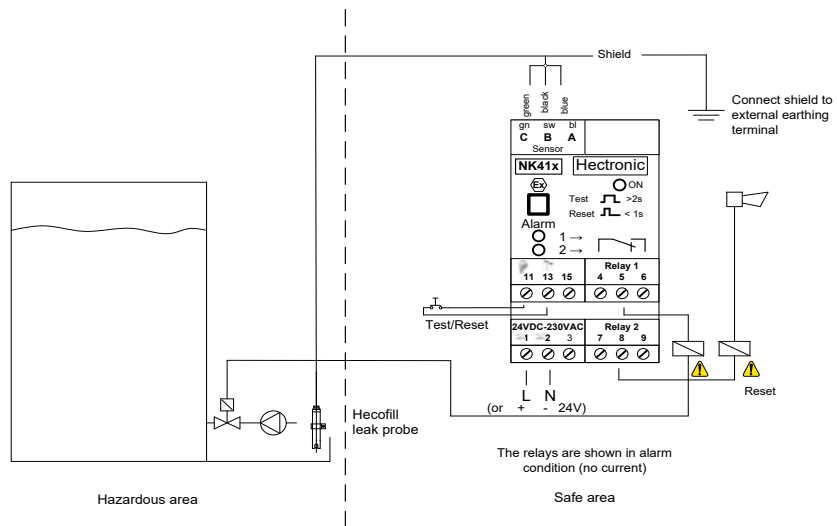

Warning! Use the terminals on the **bottom left** of the controller to connect the supply line. Connecting to the wrong terminal may destroy the device.

1.4. Technical Data

Input

Probe (sensor) circuit	Intrinsically safe [Ex ia Ga] IIC
Probe (sensor) circuit A-C	Max. internal capacity: Ci 14.4 nF Max. internal inductivity: Li 300.0 µH Group: IIC IIB IIA Inductance Lo 2.0 mH 100 mH 100 mH Capacitance Co 0.59 µF 2.1 µF 5.8 µF Maximum values: AC: U ₀ = 13.6 V; I ₀ = 11,3 mA; P _{max} = 38,5 mW
Probe (sensor) circuit B-C	Max. internal capacity: Ci 14.4 nF Max. internal inductivity: Li 300.0 µH Group: IIC IIB IIA Inductance Lo 2.0 mH 97 mH 100 mH Capacitance Co 0.52 µF 1.1 µF 4.4 µF Maximum values: BC: U ₀ = 13.6 V; I ₀ = 54,3 mA; P _{max} = 184,8 mW
AFS (overflow prevention system) circuit A-C	Max. internal capacity: Ci 14.4 nF Max. internal inductivity: Li 300.0 µH Group: IIC IIB IIA Inductance Lo 5.0 mH 100 mH 100 mH Capacitance Co 0.53 µF 2.3 µF 6.1 µF Maximum values: AC: U ₀ = 13.6 V; I ₀ = 0.14 mA; P _{max} = 0,47 mW
AFS (overflow prevention system) circuit B-C	Max. internal capacity: Ci 14.4 nF Max. internal inductivity: Li 300.0 µH Group: IIC IIB IIA Inductance Lo 5.0 mH 100 mH 100 mH Capacitance Co 0.53 µF 2.3 µF 6.1 µF Maximum values: BC: U ₀ = 13.6 V; I ₀ = 0.14 mA; P _{max} = 0,47 mW
Cable data	≤ 200 Ohm, ≤ 100 nF, ≤ 1 mH
Cable length	With cable 0,75 mm ² shielded max. 1000 m
Connection values	According to Hectronic IR specification
Remote Acknowledge/ Test	With external button (cable length < 10 m)

Output

Alarm 1	Potential free relay contact
Alarm 2	Potential free relay contact, confirmable
Contact load	AC; 5A/230V DC; 5A/30V, 1A/60V, 0,5A/100V
AFS connection	For connecting to tank trucks with AFS system (CH)



Supply network	20...253VAC, 50...60Hz, 2W 22-253VDC	
LED Indicator	ON Alarm 1 Alarm 2	green, ready for operation red red
Button	Reset < 1 sec. Test > 2 sec.	Confirm Alarm 2 Test alarm function
Operating temperature	-25...+60°C	
Connection	Screw terminals, max. 2,5 mm ²	
Environmental conditions	Usage within buildings Place of installation up to 2,000 m high Relative humidity 25 - 95 % (non-condensing) Degree of contamination 2 (acc. EN 61010)	

DIN Rail mounting housing

	For mounting on DIN rail T 35 (EN 50022)
Material housing	Polyamide
Protection category	IP 20 (DIN/EN 60529)
Dimensions	W 35 x H 115 x D 100 mm

1.5. Type Plate

Hectronic GmbH Allmendstr. 15 D-79848 Bonndorf		
NK41x	Level controller	
Product no.:	5010.01001x00	
Serial no.:	xxxxxx	0035
Year of construction:	???	
U:	20-253VAC (50-60Hz) P: 2 W	
	22-253VDC	
Relay		
Output:	AC: 5A / 230V DC: 5A / 30V, 1A / 60V, 0.5A / 100V approx. 5V DC, Ri 10k	
Button:		
Sensor, Ex	II (1) G [Ex ia Ga] IIC	
	Certificate no.: SEV 17 ATEX 0152 X IECEX SEV 17.0016X	
	Follow operation instructions.	
KVU no.: 302.028	Z-65.14-571 (WHG)	

Installation

2. Installation16

2.1. Device Dimensions16

2.2. Mounting16

2.3. Installation17

2.3.1. Application Example NK41117

2.3.2. Application Example NK41218

2.4. Connection20

2.4.1. Connection of HecoFill Probe20

2.4.2. Connection of AFS Connector for Tank Trucks20

2.4.3. Connection of External Button for Test/Reset20



2. Installation

2.1. Device Dimensions

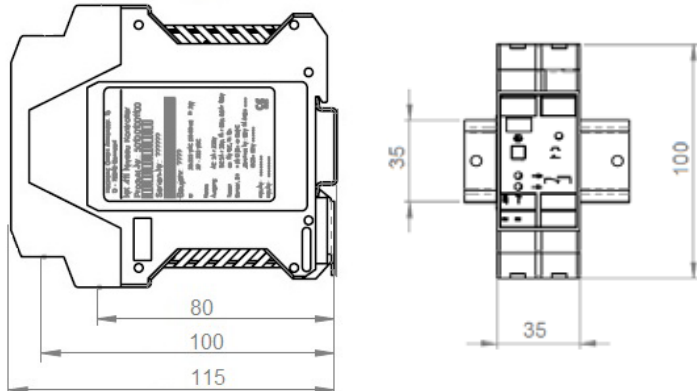

2.2. Mounting

The NK41x level controller is attached to a symmetrical DIN rail (top-hat rail, complies with EN 50022) by snapping the controller on the rail. To do so, pull down the spring clip on the back of the device, hinge the controller at the upper side of the rail, press the controller against the bottom side of the DIN rail and release the spring clip again.



The NK411 / NK412 has no switch; for this reason there must be a switch or circuitbreaker in the building installation that is suitably arranged and easily accessible for the user. Furthermore, the switch has to be marked as a disconnector for the device.



Devices can be mounted side-by-side without any clearance in the control cabinet.

2.3. Installation

You can connect one HecoFill probe to each Level controller NK41x.

2.3.1. Application Example NK411

Special limit indicator with connector for tank trucks with overflow prevention mechanism AFS

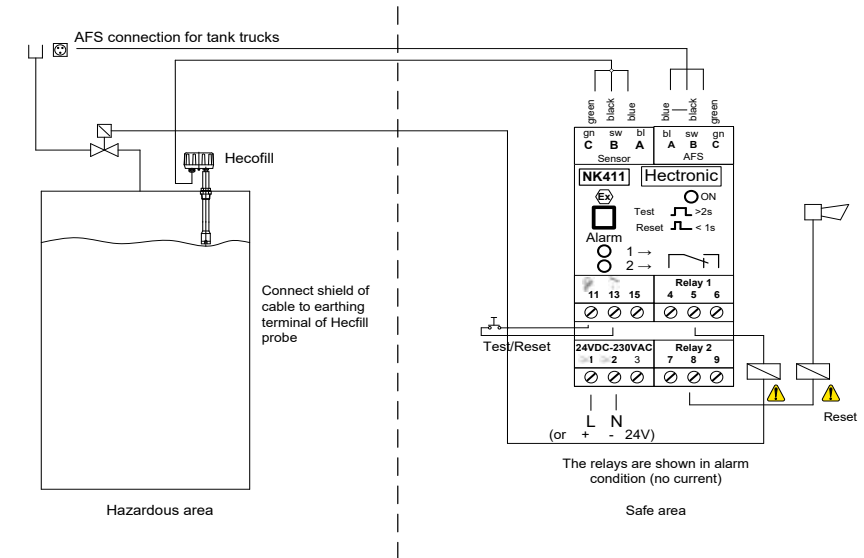

Warning! Use the terminals on the **bottom left** of the controller to connect the supply line. Connecting to the wrong terminal may destroy the device.

1

2

3

4

5

6

7

2.3.2. Application Example NK412

2.3.2.1. Special Limit Indicator

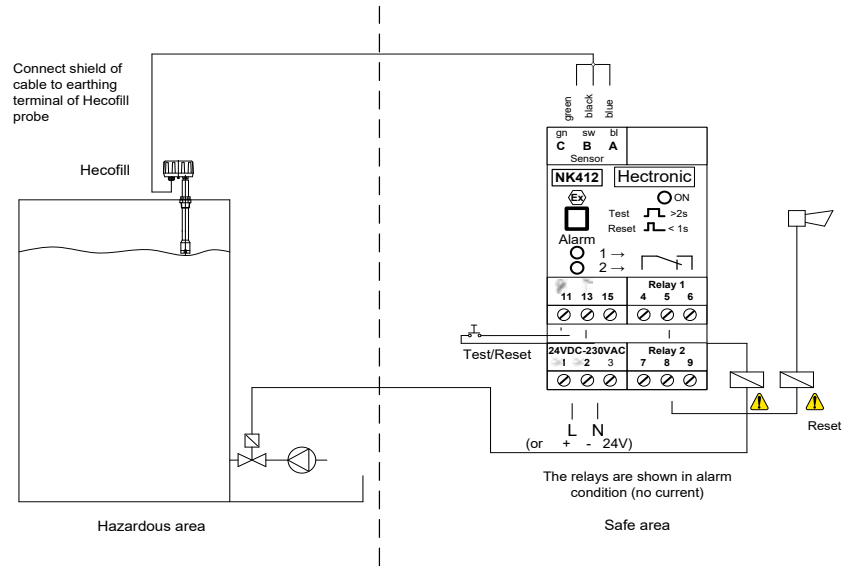

Warning! Use the terminals on the bottom left of the controller to connect the supply line. Connecting to the wrong terminal may destroy the device.

2.3.2.2. Leak Detection System

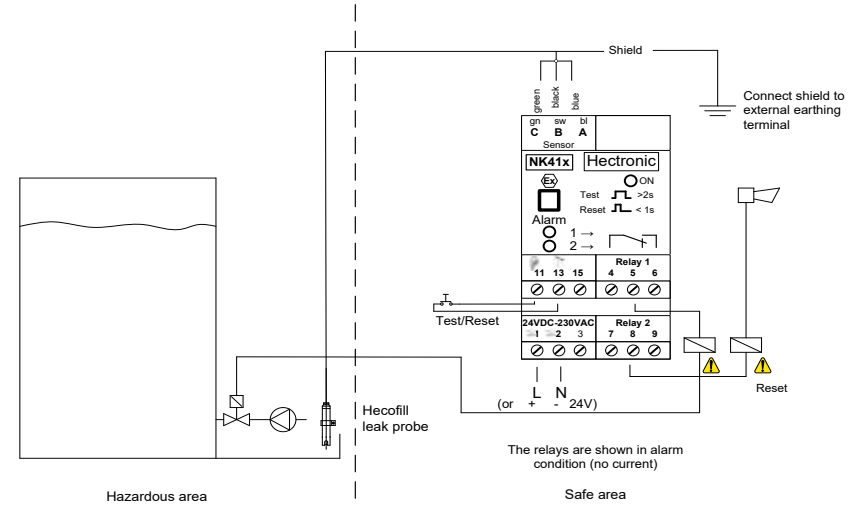

Warning! Use the terminals on the **bottom left** of the controller to connect the supply line. Connecting to the wrong terminal may destroy the device.

1

2

3

4

5

6

7

2.4. Connection



Please follow the instructions in standard EN 60079-14:2014 „Explosive atmospheres – Part 14: Electrical installations design, selection and erection!

2.4.1. Connection of HecoFill Probe

The HecoFill probe is connected by using a 3-pole cable (shielded, blue, 0.75 mm²). The shield must be connected on the probe side (red head housing). If leakage probes have permanently connected cable ends the shield must be connected to the external earthing terminal.



Lightning protection: When installing the probe in above-ground containers for stored items with a flash point <55 °C (Ex-Zone 0), lightning protection facilities must be installed. Please follow the relevant installation instructions. The max. cable length is mentioned in chapter 1.4 “Technical Data”!

2.4.2. Connection of AFS Connector for Tank Trucks

AFS (overflow prevention system) connection to the standard socket of a tank truck with AFS (overflow prevention system) system is made through a 3-pole plug (min. 0.5 mm²).

2.4.3. Connection of External Button for Test/Reset

It is possible to acknowledge (reset) the alarms through an external button. Use terminal 11 and 13 (approx. 5V DC) to connect the external button to the device or system.



For further information, please read chapter 4 „Getting started and operation“.

Signals and Control Elements

3. Signals and Control Elements22

3.1. Signals22

3.2. Control Elements.....23

1

2

3

4

5

6

7

3. Signals and Control Elements

The NK41x level controller has the following signals and control elements:

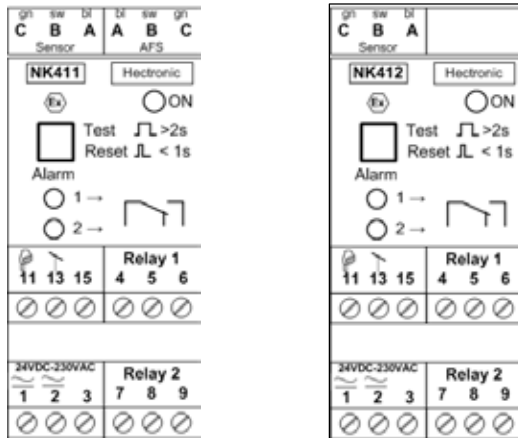

NK411 (with AFS)

NK412 (Standard)

The serial number of the type plate will be also shown on the front side.



The relays are shown in alarm condition (no current).

3.1. Signals

No.	Signals	LED display	Probe submerged/ not submerged	Description
1	LED ON	Dark		<ul style="list-style-type: none"> No power supply Device is faulty
		Green continuous illumination		Ready for operation
		Flashing green		Controller is faulty
2	LED Alarm 1	Dark	Not submerged	Normal operation
		Flashing red	Submerged	Not acknowledged
		Red continuous illumination	Submerged	Acknowledged
3	LED Alarm 2	Dark	Not submerged	Normal operation
		Flashing red	Submerged	Not acknowledged
		Dark	Submerged	Acknowledged

3.2. Control Elements

No.	Control element	Function	Description
4	Button Test/Reset	Test	Press and hold the button (>2 seconds) to carry out a functional test.
		Reset	Press button briefly (<1 seconds) to acknowledge an alarm.



An external button can be connected to the terminals 11 and 13 (cable length max. 10 m). The external button has the same function as the internal button.

1

2

3

4

5

6

7

Notes:

Large empty grid area for notes.

Operation

- 4. Operation26
 - 4.1. Operation.....26
 - 4.2. Periodic Functional Testing.....27
 - 4.3. Alarm Reset Mode27
 - 4.3.1. Without Jumper between Terminals 13 and 15 (Standard)27
 - 4.3.2. With Jumper between Terminals 13 and 15.....27

1

2

3

4

5

6

7

4. Operation



Please follow the instructions in standard "EN 60079-14:2014 Explosive areas part 14: Attachment A knowledge, expertise, and competencies of responsible personnel, mechanics / technicians, and planners"!

4.1. Operation

1. Connect the NK41x controller and HecoFill probe according to the installation plan.



Relevant installation plans and information on the NK 41x level controller connections are provided in chapter 2.3, "Installation"!

2. Put the device under voltage. The green LED ON indicates that the level controller is connected to the power supply and ready for operation. The **Alarm 1** und **Alarm 2** relays energize, and the red LED is off (no alarm), if the HecoFill probe is not submerged.
3. Carry out a functional test. To do so, the HecoFill probe must be connected properly and not be submerged!



Warning! You can only carry out a functional test if the probe is not submerged!

Press and hold the **Test/Reset** button for at least two seconds. After two seconds the **Alarm 1** and **Alarm 2** relays will de-energize for about four seconds and the red **Alarm 1** and **Alarm 2** LED will flash.

4. Submerge the probe. The Alarm 1 and Alarm 2 relays now have to de-energize (= Alarm) and both red **Alarm 1** and **Alarm 2** LEDs will flash.
5. To acknowledge the alarm, you briefly have to press the **Test/Reset**-button (< 1 second). After the acknowledgement the red **Alarm 1** LED will be continuously illuminated and the relay 1 will remain de-energized. The red **Alarm 2** LED turns off and relay 2 will re-energize.
6. When the probe is no longer submerged, both relays will re-energize and both LEDs turn off (without jumper to remain an alarm pending until it is acknowledged).



The NK41x level controller automatically performs regular self-tests several times per second. However, these tests will **not be notified!**

4.2. Periodic Functional Testing

The functionality of the measuring system (NK41x and HecoFill probe) must be tested at regular inspection intervals in compliance with legal requirements.

The NK41x level controller will automatically perform periodic self-tests when the probe is not submerged (several times per second). As a liquid analogue test, it includes the entire measuring system of NK41x, from the probe cable to the HecoFill probe tip.

The alarm function must be checked once a year. The test is carried out without removing the HecoFill probe by simply pressing the **Test/Reset** button.

Testing:



The test can only be carried out when the probe is not submerged (no alarm).

1. Press the **Test/Reset** button on the NK41x controller for more than 2 seconds.
2. An alarm display will now be triggered:
The red LED will flash (alarm condition) and the relays will de-energize.
3. After four seconds the system will return to the normal operation.

4.3. Alarm Reset Mode



After you have changed the alarm reset mode you have to restart the NK41x. For this, briefly disconnect the controller from the power supply.

4.3.1. Without Jumper between Terminals 13 and 15 (Standard)

The alarm will automatically stop if the liquid level drops and the HecoFill probe is not dipped into liquid any longer.

4.3.2. With Jumper between Terminals 13 and 15

If there is an active alarm (probe submerged), you can manually acknowledge (reset) **Alarm 2** using the internal or external button.

Alarm 1 (and **Alarm 2**, if not yet acknowledged) will continue to operate until manual reset (via the the internal or external button), even when the liquid level drops and the probe is not dipped into liquid any longer.

Notes:

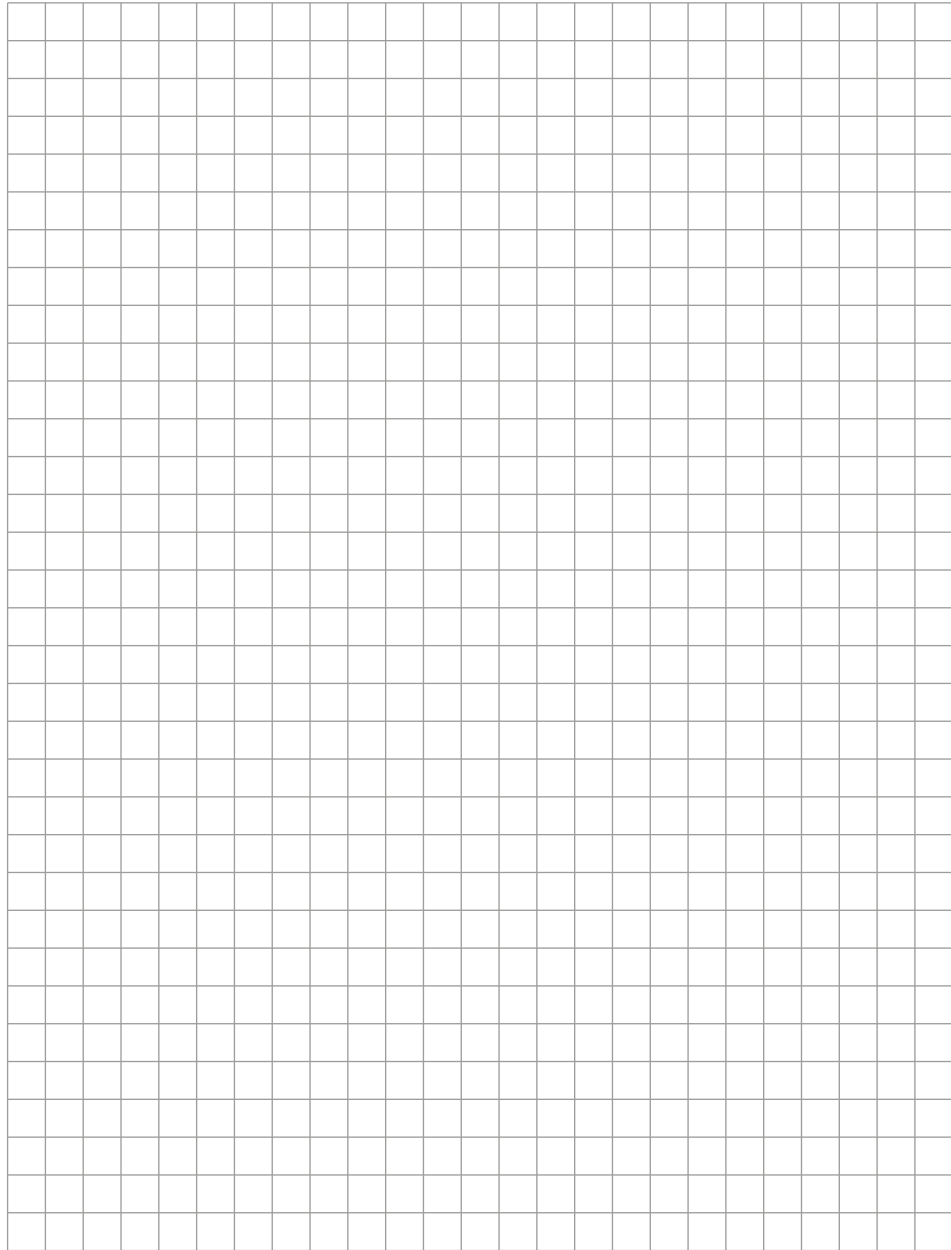

LED Indicators

5. LED indicators 30

1

2

3

4

5

6

7

5. LED Indicators

The following table shows the system's status indicated by the LED lights when in operation. It will also help you to recognize faults and their causes:

LED display			Alarm description	Cause of fault
ON (green)	Alarm 1 (red)	Alarm 2 (red)		
Off	Off	Off		<ul style="list-style-type: none"> No power to device Controller faulty
Green	Off	Off		<ul style="list-style-type: none"> Probes connected, not submerged
Green	Flashing	Flashing	Both alarm relays are de-energized, acknowledgement possible	<ul style="list-style-type: none"> Probe submerged
Green	Red	Off		<ul style="list-style-type: none"> Probe submerged and already acknowledged (reset)
Flashing	Dark	Dark	Both alarm relays are de-energized	<ul style="list-style-type: none"> Controller faulty

LED display			Alarm description	Cause of fault
ON (green)	Alarm 1 (red)	Alarm 2 (red)		
Green	Flashing slowly	Red		<ul style="list-style-type: none"> Probe not or not properly connected Probe faulty Insulation fault on probe cable Short circuit/power failure on probe cable External light impact Probe outside of tolerance Cable too long Probe analysis not working due to faulty controller Short circuit on alarm signal line
Green	Flashing quickly	Red	Both alarm relays are de-energized, acknowledgement possible	<ul style="list-style-type: none"> Internal error (EX part does not react)
Green	Flashing	Flashing	Both alarm relays are flashing	<ul style="list-style-type: none"> External button short circuit

1

2

3

4

5

6

7

IECEX Certificate of Conformity	
Certificate No.: IECEX SEV 17.0016X	Page 4 of 4
Date of issue: 2021-03-16	Issue No: 2
DETAILS OF CERTIFICATE CHANGES (for issues 1 and above) Correction of ratings	
Annex: IECEX SEV 17.0016X App I2.pdf	
	

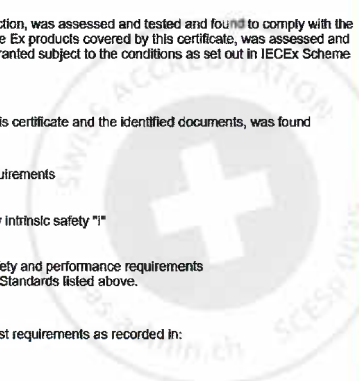
IECEX Certificate of Conformity	
Certificate No.: IECEX SEV 17.0016X	Page 2 of 4
Date of issue: 2021-03-16	Issue No: 2
Manufacturer: Hectronic GmbH Allmendstrasse 15 79848 Bonndorf Germany	
Additional manufacturing locations:	
This certificate is issued as verification that a sample(s), representative of production, was assessed and tested and found to comply with the IEC Standard list below and that the manufacturer's quality system, relating to the Ex products covered by this certificate, was assessed and found to comply with the IECEX Quality system requirements. This certificate is granted subject to the conditions as set out in IECEX Scheme Rules, IECEX 02 and Operational Documents as amended	
STANDARDS : The equipment and any acceptable variations to it specified in the schedule of this certificate and the identified documents, was found to comply with the following standards	
IEC 60079-0:2017 Edition:7.0	Explosive atmospheres - Part 0: Equipment - General requirements
IEC 60079-11:2011 Edition:6.0	Explosive atmospheres - Part 11: Equipment protection by intrinsic safety "I"
This Certificate does not indicate compliance with safety and performance requirements other than those expressly included in the Standards listed above.	
TEST & ASSESSMENT REPORTS: A sample(s) of the equipment listed has successfully met the examination and test requirements as recorded in:	
Test Report: CH/SEV/ExTR17.0016/02	
Quality Assessment Report: DE/TUR/QAR09.0007/04	
	

1

2

3

4

5

6

7



Annexe to: IECEx SEV 17.0016X **Issue No.:** 2
page 1 of 2

Applicant Name: Hectronic GmbH, Tank- und Parksysteme

Electrical Apparatus: Level controller Type NK41x

Rating:

Nominal values: Um: 253 VAC / 50-60 Hz
Um: 253 VDC

Relay output: AC: 5 A @ 230 V
DC: 5 A @ 30 V / 1A @ 60 V / 0.5 A @ 100 V

Sensor circuit A-C:

Maximum output voltage	Uo	=	13.6 V
Maximum output current	Io	=	11.3 mA
Maximum output power	Po	=	38.5 mW
Linear characteristic			

Maximum internal capacity	Ci	=	14.4 nF
Maximum internal inductivity	Li	=	300.0 µH

Group	IIC	IIB	IIA
Inductance Lo	2.0 mH	100 mH	100 mH
Capacitance Co	0.59 µF	2.1 µF	5.8 µF

Sensor circuit B-C:

Maximum output voltage	Uo	=	13.6 V
Maximum output current	Io	=	54.3 mA
Maximum output power	Po	=	184.8 mW
Linear characteristic			

Maximum internal capacity	Ci	=	14.4 nF
Maximum internal inductivity	Li	=	300.0 µH

Group	IIC	IIB	IIA
Inductance Lo	2.0 mH	97 mH	100 mH
Capacitance Co	0.52 µF	1.1 µF	4.4 µF

Eurofins Electric & Electronic Product Testing AG
Swiss Certification Body

Luppenstrasse 3 Tel. +41 56 220 11 00
CH-8320 Fehraltorf CustomerCenter@eurofins.ch
www.eurofins.ch



IECEx Certificate of Conformity

Certificate No.: IECEx SEV 17.0016X

Page 3 of 4

Date of issue: 2021-03-16

Issue No: 2

EQUIPMENT:

Equipment and systems covered by this Certificate are as follows:

The function principle of the level controller is based upon the previous model NK31x and like the NK31 model it contains the power supply and the Ex barriers for Hecofill level threshold probes and for analysing their signals. Hecofill probes work according to the optoelectronic measuring principle. A glass prism refracts a ray of light. When the prism is wetted the refraction will change. This reflected signal will be detected and evaluated by the Hecofill probe and then be transmitted to the level controller via the interface. The interface from the level controller to the probe is defined as current loop interface (0.5 mA to 20 mA) and from the probe to the level controller as voltage interface.

Although the level controller is mounted outside the hazardous location, the signals of the controller's electrical equipment will enter the hazardous zone 1 and zone 2 locations. Therefore the device is divided into two parts. The intrinsically safe component contains parts whose signals enter the hazardous zone 1 and zone 2 locations and has the EPL Ga to connect a probe for zone 0. This component of the level controller is relevant for certification.

The control unit contains the rest of the electronics, such as the power supply, control elements (sensor, LED) and two relays which will switch as soon as the fluid level is reached. The controller is separated from the intrinsically-safe circuit unit by the required clearance and creepage distances.

Supply:

An integrated wide range power supply (22-253 V DC / 20-253 V AC) energized the level controller. Thus, a +24V voltage for the internal power supply is generated. A circuit module that is galvanically isolated and generates the needed 12V to run the intrinsically safe components.

Ex / Intrinsically safe component:

The Hecofill probe interface and the FDA probe simulation for overfill prevention (Abfüllsicherungssystem = AFS) is leading into the zone 1 and zone 2 areas. Thus, this component has an intrinsically safe circuit (i.e. galvanic isolated supply, Zener barriers and current limiting on the output side). The included microcontroller (PSoc) controls the analogue interfaces (current loop interface, voltage interface) and transmits the probe's status to the microcontroller in the control unit via the electrically isolated UART connection.

Control unit:

The microcontroller in the control unit controls the relays and LED on the basis of the received probe's status and analyses the condition of the internal resp. external sensor.

There is a multi-pin connector with the not needed signals from the microcontroller. These signals can later be used as additional interfaces for Tibar functionality.

Type designation:

Type: Order No.:

NK411 5010.01001100 with AFS connector

NK412 5010.01001200 without AFS connector

Ratings see Annexe to certificate

SPECIFIC CONDITIONS OF USE: YES as shown below:

- The ambient temperature range of the apparatus is -25 °C ≤ Tamb ≤ 60 °C.

- For calculation of the intrinsic safe circuit the internal capacitance of Ci = 14.4 nF and the internal inductance of Li = 300 µH must be regarded.

1

2

3

4

5

6

7

| **E&E**

Annexe to: IECEX SEV 17.0016X **Issue No.:** 2
page 2 of 2

Rating:

AFS circuit A-C:	Maximum output voltage	Uo	=	13.6 V
	Maximum output current	Io	=	0.14 mA
	Maximum output power	Po	=	0.47 mW
	Linear characteristic			
Maximum internal capacity		Ci	=	14.4 nF
Maximum internal inductivity		Li	=	300.0 µH
AFS circuit B-C:	Group	IIC	IIB	IIA
	Inductance Lo	5.0 mH	100 mH	100 mH
	Capacitance Co	0.53 µF	2.3 µF	6.1 µF
	Maximum output voltage	Uo	=	13.6 V
Maximum output current	Io	=	0.14 mA	
Maximum output power	Po	=	0.47 mW	
Linear characteristic				
Maximum internal capacity		Ci	=	14.4 nF
Maximum internal inductivity		Li	=	300.0 µH
Classification of installation and use:	stationary			
	Ingress protection:	IP20		
	Rated ambient temperature range (°C):	-25 °C ≤ Tamb ≤ 60 °C		
	Rated ambient temperature range (°C) for Ex Components	N/A		

Luppmensstrasse 3 Tel. +41 58 220 32 00
CH-8320 Fehraltorf CustomerCenter@eurofins.ch
www.eurofins.ch

| **E&E**

Appendix

(13)

(14) **EU-Type Examination Certificate no. SEV 17 ATEX 0152 X**

(15) **Description of product**

The function principle of the level controller is based upon the previous model NK31x and like the NK31 model it contains the power supply and the Ex barriers for Hecofill level threshold probes and for analysing their signals.

Hecofill probes work according to the optoelectronic measuring principle. A glass prism refracts a ray of light. When the prism is wetted the refraction will change. This reflected signal will be detected and evaluated by the Hecofill probe and then be transmitted to the level controller via the interface. The interface from the level controller to the probe is defined as current loop interface (0.5 mA to 20 mA) and from the probe to the level controller as voltage interface.

Although the level controller is mounted outside the hazardous location, the signals of the controller's electrical equipment will enter the hazardous zone 1 and zone 2 locations. Therefore the device is divided into two parts.

The intrinsically safe component contains circuit parts whose signals enter the hazardous zone 1 and zone 2 locations and has the EPL Ga to connect a probe for zone 0. This component of the level controller is relevant for certification.

The control unit contains the rest of the electronics, such as the power supply, control elements (sensor, LED) and two relays which will switch as soon as the fluid level is reached. The controller is separated from the intrinsically-safe circuit unit by the required clearance and creepage distances.

Supply:
An integrated wide range power supply (22-253 V DC / 20-253 V AC) energized the level controller. Thus, a +24V voltage for the internal power supply is generated. A circuit module that is galvanically isolated and generates the needed 12V to run the intrinsically safe components.

Ex / intrinsically safe component:
The Hecofill probe interface and the FDA probe simulation for overflow prevention (Abfüllsicherungssystem = AFS) is leading into the zone 1 and zone 2 areas. Thus, this component has an intrinsically safe circuit (i.e. galvanic isolated supply, Zener barriers and current limiting on the output side). The included microcontroller (PSoc) controls the analogue interfaces (current loop interface, voltage interface) and transmits the probe's status to the microcontroller in the control unit via the electrically isolated UART connection.

Control unit:
The microcontroller in the control unit controls the relays and LED on the basis of the received probe's status and analyses the condition of the internal resp. external sensor.

There is a multi-pin connector with the not needed signals from the microcontroller. These signals can later be used as additional interfaces for Tibar functionality.

Type designation:
Type: Order No.:
NK411 5010.01001100 with AFS connector
NK412 5010.01001200 without AFS connector

www.eurofins.ch Fehraltorf, 2021-03-04 Issue: 2 page 2 of 4

1

2

3

4

5

6

7

E&E

Rating:

Nominal values: Um: 253 VAC / 50-60 Hz
Um: 253 VDC

Relay output: AC: 5 A @ 230 V
DC: 5 A @ 30 V / 1A @ 60 V / 0.5 A @ 100 V

Sensor circuit A-C:

Maximum output voltage	Uo	=	13.6 V
Maximum output current	Io	=	11.3 mA
Maximum output power	Po	=	38.5 mW
Linear characteristic			
Maximum internal capacity	CI	=	14.4 nF
Maximum internal inductivity	LI	=	300.0 µH

Group	IIC	IIB	IIA
Inductance Lo	2.0 mH	100 mH	100 mH
Capacitance Co	0.59 µF	2.1 µF	5.8 µF

Sensor circuit B-C:

Maximum output voltage	Uo	=	13.6 V
Maximum output current	Io	=	54.3 mA
Maximum output power	Po	=	184.8 mW
Linear characteristic			
Maximum internal capacity	CI	=	14.4 nF
Maximum internal inductivity	LI	=	300.0 µH

Group	IIC	IIB	IIA
Inductance Lo	2.0 mH	97 mH	100 mH
Capacitance Co	0.52 µF	1.1 µF	4.4 µF

AFS circuit A-C:

Maximum output voltage	Uo	=	13.6 V
Maximum output current	Io	=	0.14 mA
Maximum output power	Po	=	0.47 mW
Linear characteristic			
Maximum internal capacity	CI	=	14.4 nF
Maximum internal inductivity	LI	=	300.0 µH

Group	IIC	IIB	IIA
Inductance Lo	5.0 mH	100 mH	100 mH
Capacitance Co	0.53 µF	2.3 µF	6.1 µF

AFS circuit B-C:

Maximum output voltage	Uo	=	13.6 V
Maximum output current	Io	=	0.14 mA
Maximum output power	Po	=	0.47 mW
Linear characteristic			
Maximum internal capacity	CI	=	14.4 nF
Maximum internal inductivity	LI	=	300.0 µH

Group	IIC	IIB	IIA
Inductance Lo	5.0 mH	100 mH	100 mH
Capacitance Co	0.53 µF	2.3 µF	6.1 µF

www.eurofins.ch

Fehraltorf, 2021-03-04

Issue: 2

page 3 of 4

E&E

EU-Type Examination Certificate

- (1)
- (2) Equipment or protective system intended for use in potentially explosive atmospheres - **Directive 2014/34/EU**
- (3) Certificate number: **SEV 17 ATEX 0152 X**
- (4) Product: Level controller
Type NK41x
- (5) Manufacturer: Hectronic GmbH
- (6) Address: Allmendstrasse 15, 79848 Bonndorf, Germany
- (7) The equipment and any acceptable variation thereto is specified in the schedule to this certificate and the documents therein referred to.
- (8) Eurofins, notified body No. 1258, in accordance with article 17 of Directive 2014/34/EU of the European parliament and of the council, dated 26 February 2014, certifies that this product has been found to comply with the essential health and safety requirements relating to the design and construction of products intended for use in potentially explosive atmospheres given in Annex II to the Directive.
The examination and test results are recorded in confidential report no 16-Ex-0044.01, 19-Ex-0115.X03
- (9) Compliance with the essential health and safety requirements has been assured by compliance with:
EN IEC 60079-0:2018
EN 60079-11:2012
Except in respect of those requirements listed at item 18 of the schedule.
- (10) If the sign «X» is placed after the certificate number, it indicates that the product is subjected to special conditions for safe use specified in the schedule to this certificate. The sign "U" is placed after the certificate number. It indicates that this certificate must not be mistaken for a certificate intended for an equipment or protective system. This partial certification may be used as a basis for certification of an equipment or protective system.
- (11) This EU type examination certificate relates only to design and construction of the specified product. Further requirements of this directive apply to the manufacturing process and supply of this product. These are not covered by this certificate.
- (12) The marking of the product shall include the following:

II (1) G [Ex ia Ga] IIC

Eurofins Electric & Electronic Product Testing AG
Notified Body ATEX

Martin Plüss
Product Certification

www.eurofins.ch

Fehraltorf, 2021-03-04

Issue: 2

Page 1 of 4



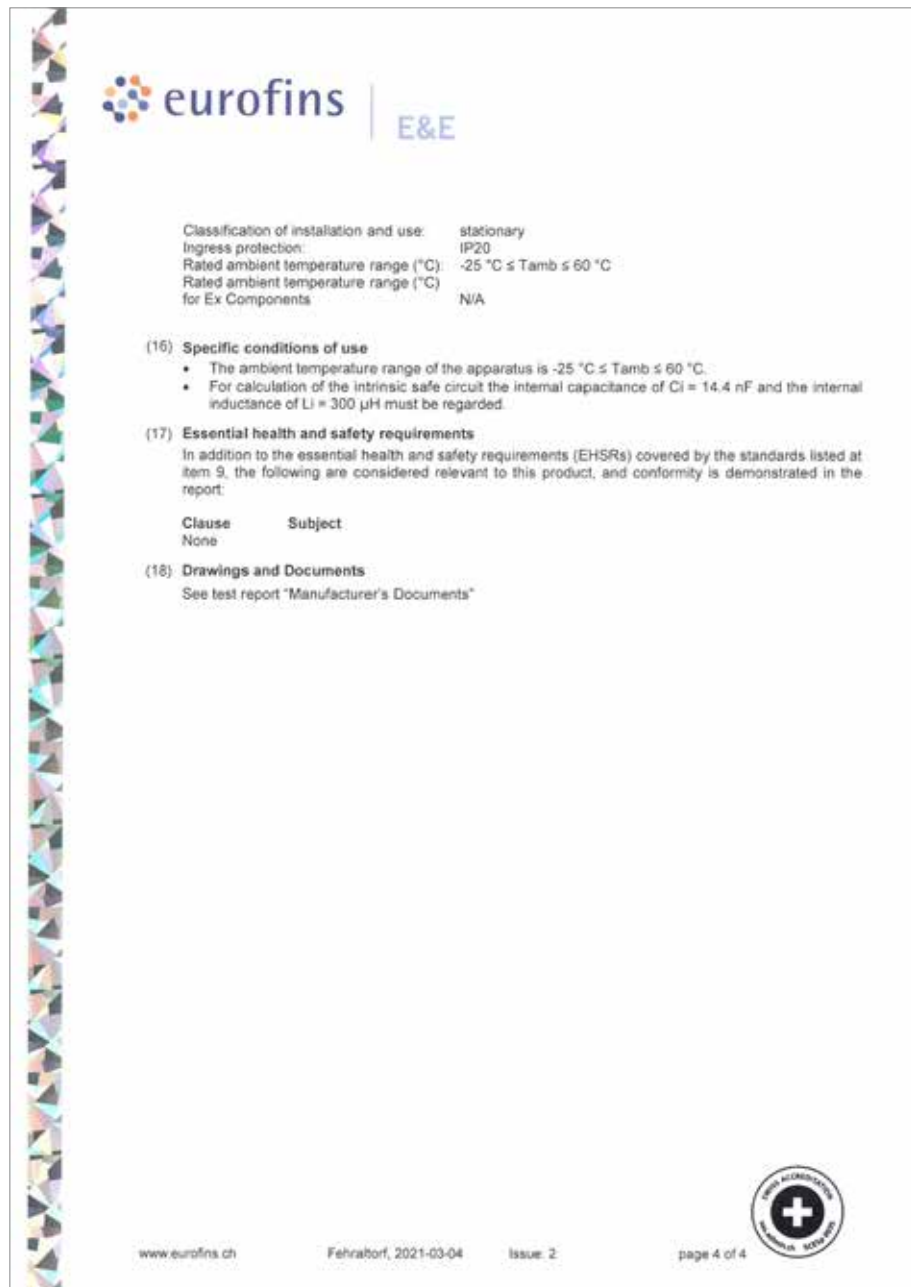

 | **E&E**

Classification of installation and use: stationary
 Ingress protection: IP20
 Rated ambient temperature range (°C): $-25\text{ °C} \leq T_{amb} \leq 60\text{ °C}$
 Rated ambient temperature range (°C) for Ex Components: N/A

(16) Specific conditions of use

- The ambient temperature range of the apparatus is $-25\text{ °C} \leq T_{amb} \leq 60\text{ °C}$.
- For calculation of the intrinsic safe circuit the internal capacitance of $C_i = 14.4\text{ nF}$ and the internal inductance of $L_i = 300\text{ μH}$ must be regarded.

(17) Essential health and safety requirements
 In addition to the essential health and safety requirements (EHSRs) covered by the standards listed at item 9, the following are considered relevant to this product, and conformity is demonstrated in the report:

Clause	Subject
None	

(18) Drawings and Documents
 See test report "Manufacturer's Documents"

www.eurofins.ch Fehratof, 2021-03-04 Issue: 2 page 4 of 4



Warranty Protocol

7. Warranty Protocol.....	48
---------------------------	----

1

2

3

4

5

6

7

User Manual

Level Controller

NK411 / NK412

Edition: 06/2023

Responsible for the contents: Product Management

Hectronic GmbH
Allmendstrasse 15
D-79848 Bonndorf

Tel. +49 7703 9388-0
Fax +49 7703 9388-60

mail@hectronic.com

www.hectronic.com